

INTERIOR
(PARKING)

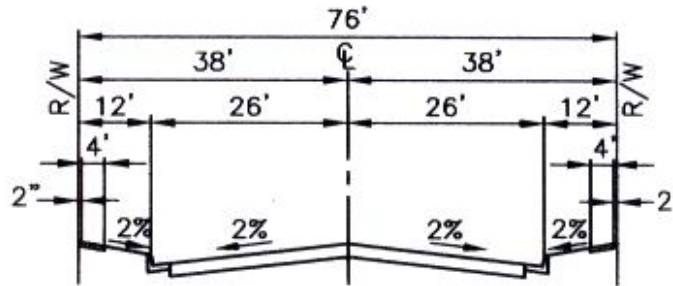

INTERIOR (INDUSTRIAL)
(PARKING)

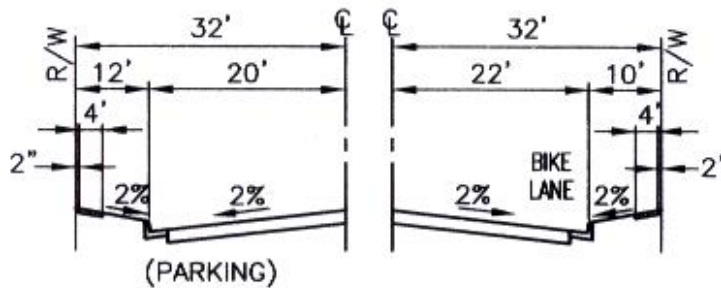

COLLECTOR

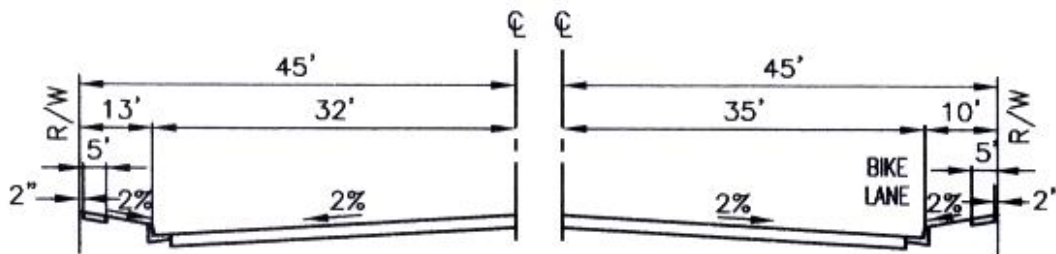

SECONDARY

REC'D <i>[Signature]</i> DEPUTY CITY ENGINEER	1/12/04 DATE	APP. <i>[Signature]</i> D.P.W. / CITY ENGINEER	1/13/04 DATE	A	4/14/04 REVISED	<i>[Signature]</i> BY
CITY OF ANAHEIM DEPARTMENT OF PUBLIC WORKS						
STREET AND HIGHWAY SECTIONS					STANDARD DETAIL NO. 160-A	
USE WITH STANDARD SPECIFICATIONS FOR PUBLIC WORKS CONSTRUCTION					SHEET 1 OF 3	

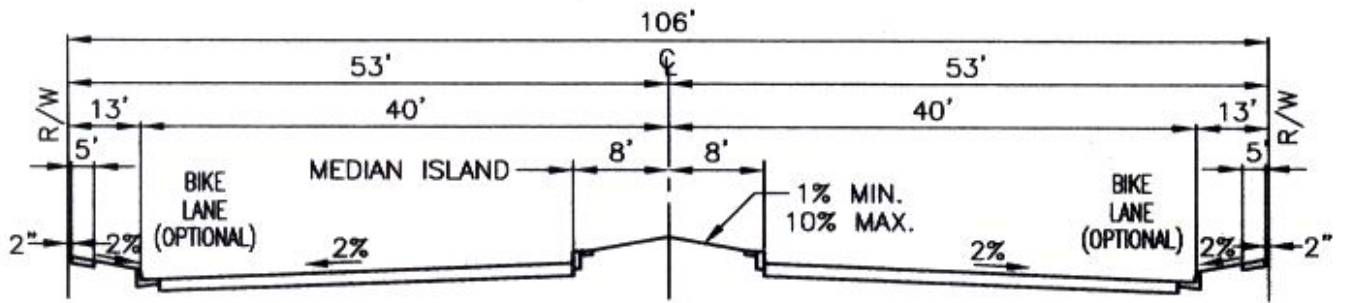

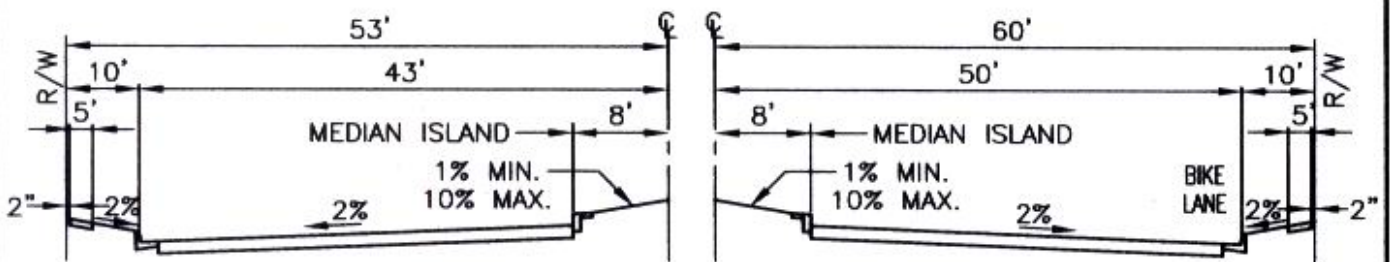

PRIMARY (FOUR LANES)

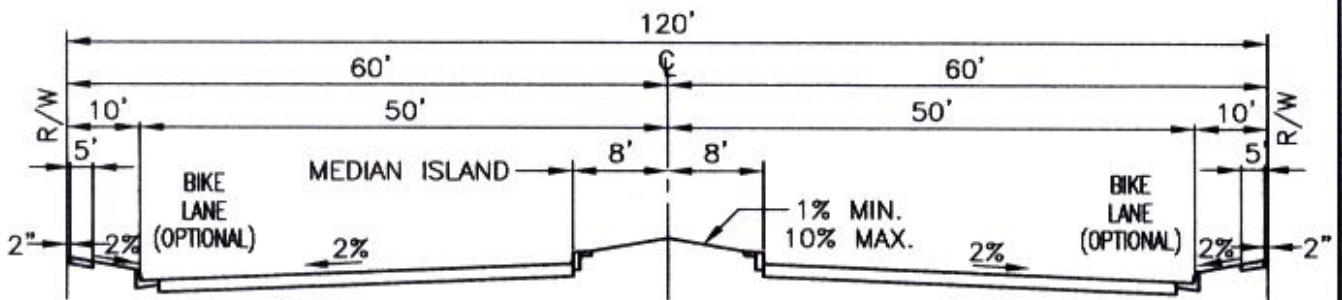

PRIMARY (SIX LANES)

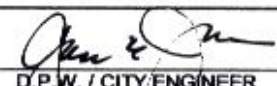

MAJOR (SIX LANES)

REC'D  DEPUTY CITY ENGINEER	1/12/04 DATE	APP.  D.P.W. / CITY ENGINEER	1/13/04 DATE	A	4/14/04  REVISED BY
CITY OF ANAHEIM DEPARTMENT OF PUBLIC WORKS					
STREET AND HIGHWAY SECTIONS				STANDARD DETAIL NO. 160-A	
USE WITH STANDARD SPECIFICATIONS FOR PUBLIC WORKS CONSTRUCTION				SHEET 2 OF 3	

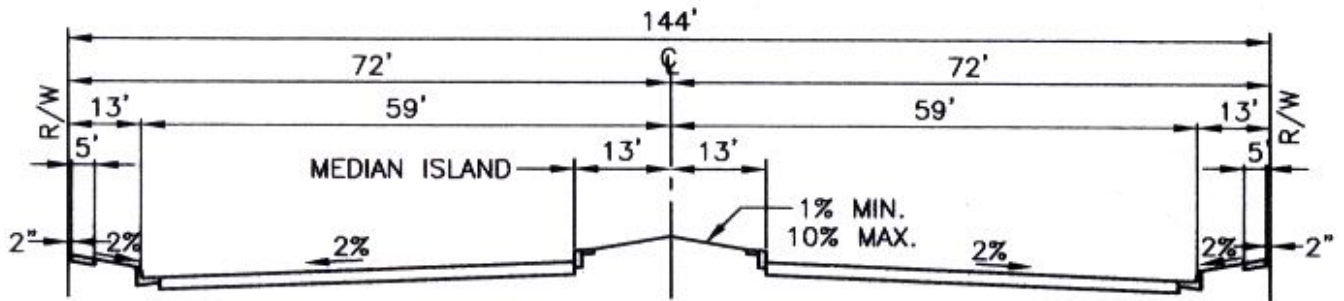

MAJOR (EIGHT LANES)

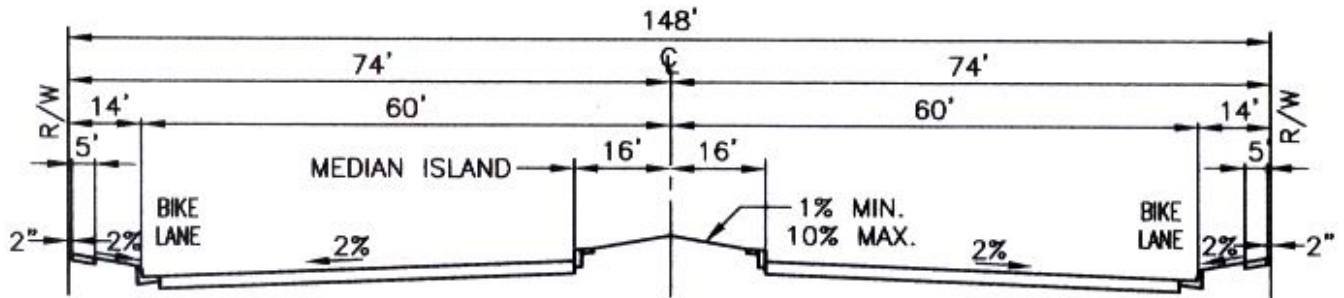

SCENIC EXPRESSWAY

NOTES:

1. PAVEMENT SECTIONS SHALL BE DETERMINED BY SOIL "R" VALUE AND TRAFFIC INDEX AND SHALL BE SHOWN ON THE PROJECT PLANS.
2. MINIMUM PAVEMENT SECTIONS ARE AS FOLLOWS:
 - A) INTERIOR: 4" A.C. OVER 4" A.B.
 - B) INTERIOR (INDUSTRIAL) AND COLLECTOR: 4" A.C. OVER 6" A.B.
 - C) SECONDARY AND PRIMARY (4-LANE): 6" A.C. OVER 6" A.B.
 - D) PRIMARY (6-LANE) AND MAJOR (6-LANE): 6" A.C. OVER 8" A.B.
 - E) MAJOR (8-LANE) AND SCENIC EXPRESSWAY: 8" A.C. OVER 8" A.B.
3. OPTIONAL BIKE LANE SHALL BE REQUIRED AS DIRECTED BY THE CITY ENGINEER.
4. NO PARKING UNLESS OTHERWISE NOTED.
5. REFERENCE IS MADE TO ADJUSTMENTS TO THE SECTIONS BY ADOPTED CIRCULATION ELEMENT EXCEPTIONS, SPECIFIC PLAN DOCUMENTS, PRECISE ALIGNMENTS AND MASTER PLANS.

REC'D <i>[Signature]</i> DEPUTY CITY ENGINEER	1/12/04 DATE	APP. <i>[Signature]</i> D.P.W. / CITY ENGINEER	1/13/04 DATE	A	4/14/04 REVISED	BY
CITY OF ANAHEIM DEPARTMENT OF PUBLIC WORKS						
STREET AND HIGHWAY SECTIONS					STANDARD DETAIL NO. 160-A	
USE WITH STANDARD SPECIFICATIONS FOR PUBLIC WORKS CONSTRUCTION					SHEET 3 OF 3	